

- -

**Managerial, Technical & Marketing Integration for SME's
Paper Summary**

Global markets changes widely and rapidly, which leads to an increase in the technical, managerial and marketing gap between local and global companies. But in spite of these changes, the local companies face a huge stress of obstacles make it stay in their place, and if this situation is fixed, so the local companies will exit from the competition at the end.

The goal of this paper is to search for scientific solutions for these obstacles in addition to introducing an executive applicable solutions because there is no time for theoretical ones.

Therefore, the adopted syllabus in this paper goes to the analyses of actual life, then ties the practical experiences with the scientific roles because they represent a guide to better decisions making.

As a result, we advice to take care of and support the local investors and producers and strength the human resources' skills. instead of depending on the foreign investments, because we have nothing to get from them but subjection to all their roles and terms.

(Infrastructure)

(1)

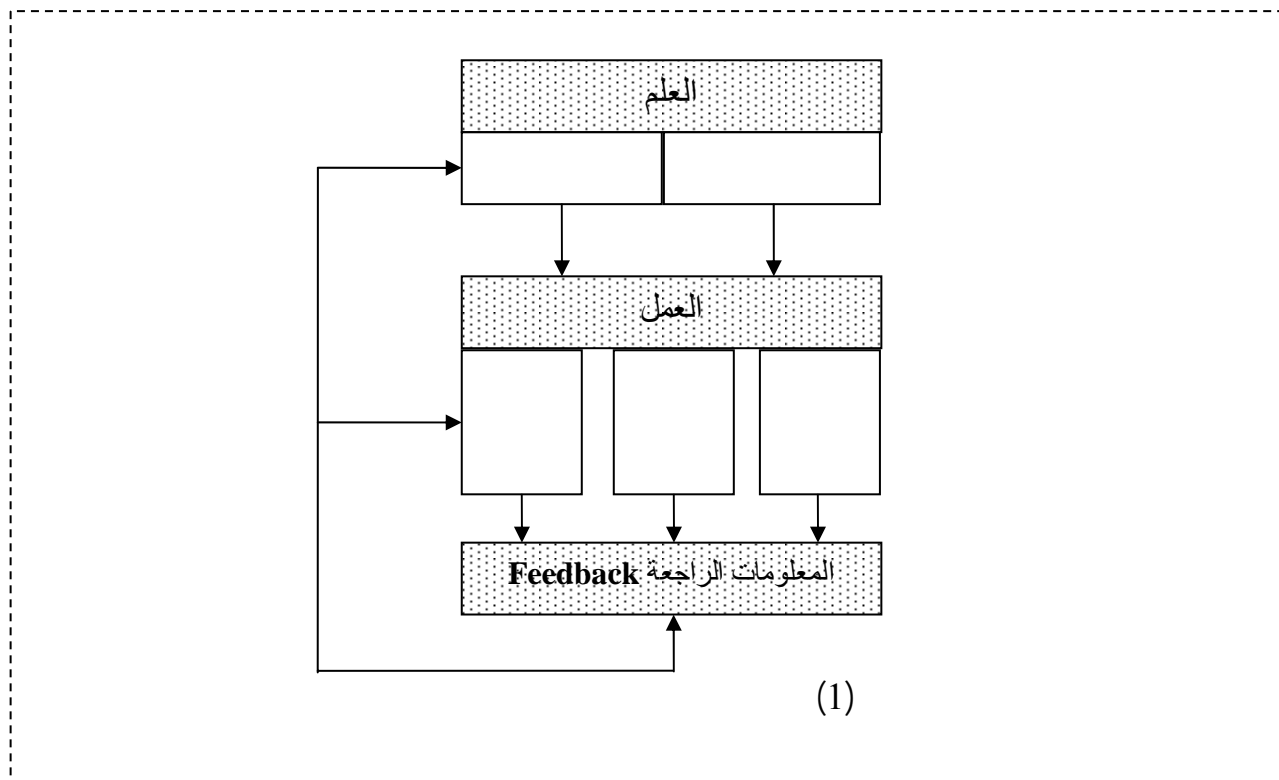

: -1

: -2

(2)

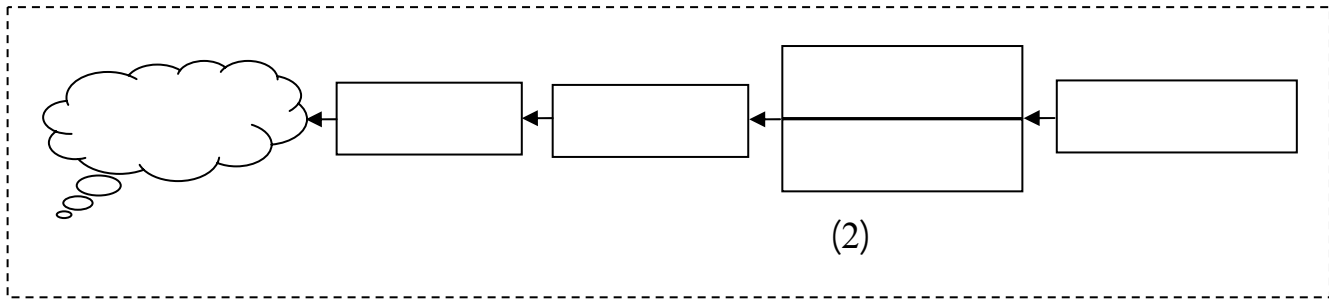

:Feedback -3

18.000

- 1
- 2
- 3

- 1
- 2
- 3
- 4
- 5

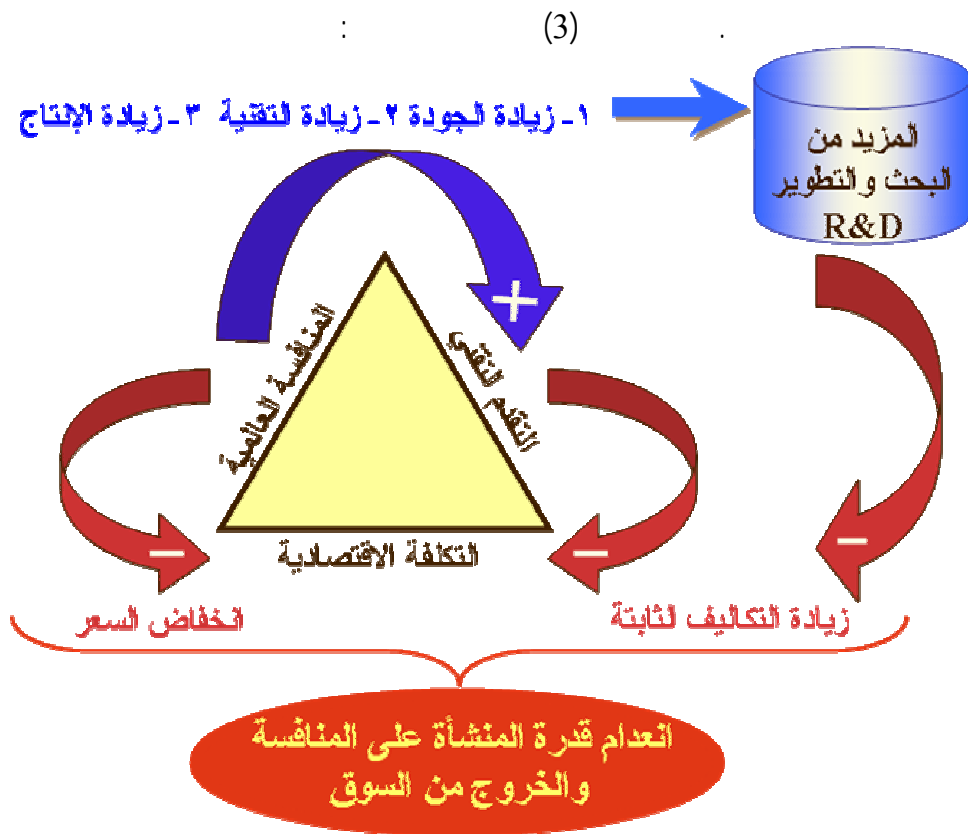

() (4):

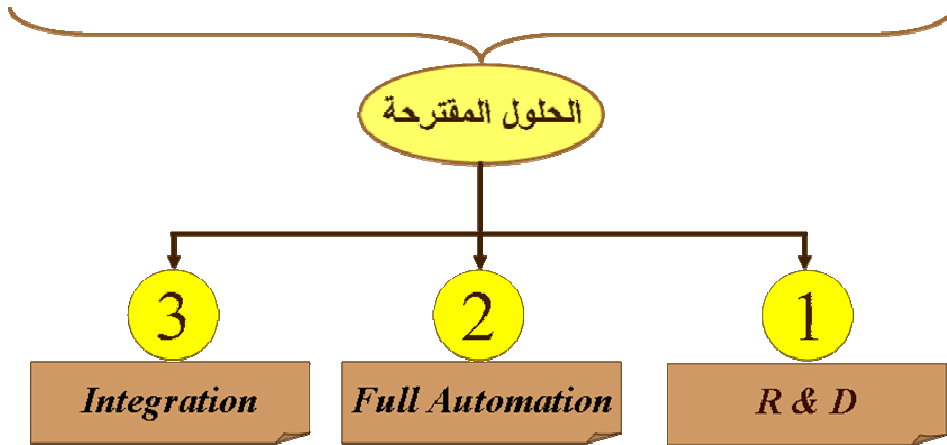

Integration & Automation

() (5):

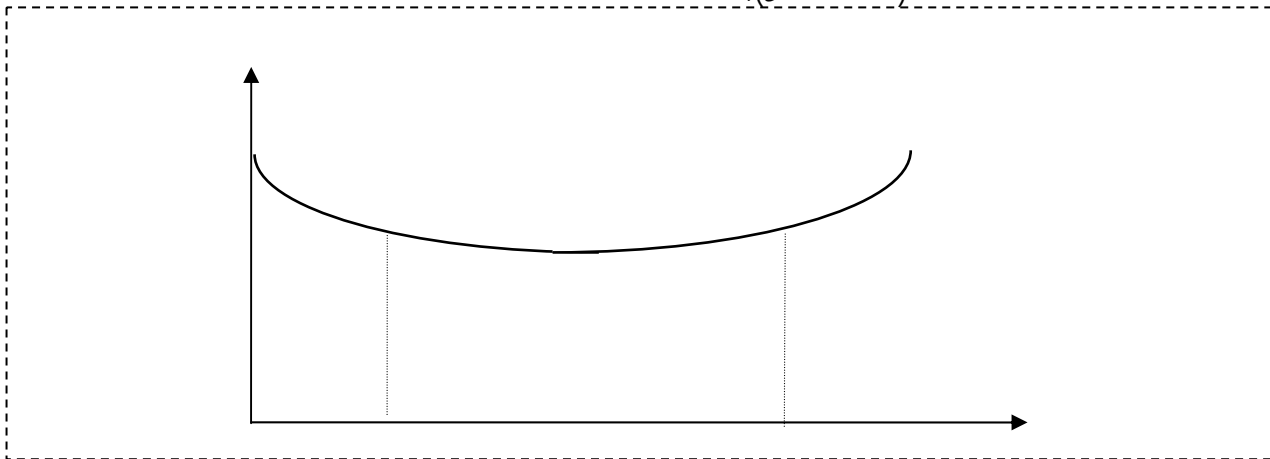

.1
:
:
.2
R&D

R&D

R&D

(USA, EU, RU)

Infrastructure

-1

-2

-3

o

-

-

-

-

-

-

o

o

"Sogo Shoshas"

-

-

.1

.2

.3

.4

.5

.6

:

.1

.2

.3

.4

(JV)

.5

.6

:

.1

.2

.3

.4

(JV)

.5

:

:

.1

.2

.3

M.I.T.

:

-

-

...

-